

BALDOR® • RELIANCE 

Product Information Packet

VHM2542T

50HP,3540RPM,3PH,60HZ,324HP,1248M,OPEN,F

Part Detail							
Revision:	H	Status:	INA/A	Change #:		Proprietary:	No
Type:	AC	Elec. Spec:	12WGY177	CD Diagram:	CD0180	Mfg Plant:	
Mech. Spec:	12E671	Layout:	12LYE671	Poles:	02	Created Date:	08-18-2009
Base:	N	Eff. Date:	03-08-2016	Leads:	9#6		

Specs			
Catalog Number:	VHM2542T	Heater Indicator:	No Heater
Enclosure:	OPEN	Insulation Class:	F
Frame:	324HP	Inverter Code:	Not Inverter
Frame Material:	Iron	KVA Code:	G
Output @ Frequency:	50.000 HP @ 60 HZ	Lifting Lugs:	Vertical Lifting Lugs
Synchronous Speed @ Frequency:	3600 RPM @ 60 HZ	Locked Bearing Indicator:	Locked Bearing
Voltage @ Frequency:	208.0 V @ 60 HZ	Motor Lead Quantity/Wire Size:	9 @ 6 AWG
	230.0 V @ 60 HZ	Motor Lead Exit:	Ko Box
	460.0 V @ 60 HZ	Motor Lead Termination:	Flying Leads
XP Class and Group:	None	Motor Type:	1248M
XP Division:	Not Applicable	Mounting Arrangement:	F1
Agency Approvals:	UR	Power Factor:	89
	CSA	Product Family:	General Purpose
Auxillary Box:	No Auxillary Box	Pulley End Bearing Type:	Ball
Auxillary Box Lead Termination:	None	Pulley Face Code:	P-Base
Base Indicator:	No Mounting	Pulley Shaft Indicator:	P-Base Groove & Key
Bearing Grease Type:	Polyrex EM (-20F +300F)	Rodent Screen:	None
Blower:	None	Shaft Extension Location:	Pulley End

Current @ Voltage:	114.000 A @ 230.0 V	Shaft Ground Indicator:	No Shaft Grounding
	124.000 A @ 208.0 V	Shaft Rotation:	Reversible
	57.000 A @ 460.0 V	Shaft Slinger Indicator:	Shaft Slinger
Design Code:	B	Speed Code:	Single Speed
Drip Cover:	Drip Cover	Motor Standards:	NEMA
Duty Rating:	CONT	Starting Method:	Direct on line
Electrically Isolated Bearing:	Not Electrically Isolated	Thermal Device - Bearing:	None
Feedback Device:	NO FEEDBACK	Thermal Device - Winding:	None
Front Face Code:	Drip Cover Mounting	Vibration Sensor Indicator:	No Vibration Sensor
Front Shaft Indicator:	None	Winding Thermal 1:	None
		Winding Thermal 2:	None

Nameplate NP1256L										
CAT.NO.	VHM2542T									
SPEC.	12E671Y177									
HP	50									
VOLTS	208-230/460									
AMP	124-114/57									
RPM	3540									
FRAME	324HP				HZ	60			PH	3
SER.F.	1.15		CODE	G	DES	B		CLASS	F	
NEMA-NOM-EFF	92.4		PF	89						
RATING	40C AMB-CONT									
CC									USABLE AT 208V	
DE	6313				ODE	6311				
ENCL	OPEN		SN							

Parts List		
Part Number	Description	Quantity
SA184979	SA 12E671Y177	1.000 EA
RA172795	RA 12E671Y177	1.000 EA
10CB3000A52	KOBX,MACH W/3.50 MTG PAT, 2.00 NPT, #26	1.000 EA
14GS1000SP	GASKET, CONDUIT BOX	1.000 EA
10XN3118K12	5/16-18 X .75 GRADE 5, ZINC PLATED	4.000 EA
HW1001A31	LOCKWASHER 5/16, ZINC PLT.591 OD, .319 I	4.000 EA
WD1000B16	T&B CX70TN OR L70P TERMINAL LUG	1.000 EA
51XF2520A08	SCREW, HEX SER SLT HD, ZN 1/4-20 X .50 L	1.000 EA
12EP1205A01	FREP, MACH - 311 BRG	1.000 EA
12AD2000A01	AIR DEFLECTOR	1.000 EA
10XN2520K08	1/4-20 X .50 GRADE #5, STL, ZINC PLATE	3.000 EA
HA4051A00	PLASTIC CAP FOR GREASE FITTING	1.000 EA
10XN5013K64	HEX HD SCREW, 1/2-13X4.00GRADE 5, ZINC P	4.000 EA
HW1001A50	LOCKWASHER 1/2, ZINC PLT.,.879 OD, .509 I	4.000 EA
HW5100A13	W4627-047 WVY WSHER	1.000 EA
10XN3816K80	3/8-16 X 5.00 HEX HD CAP SCREW GRADE 5 Z	4.000 EA
HW1001A38	LOCKWASHER 3/8, ZINC PLT .688 OD, .382 I	4.000 EA
12EP1506A02	PUEP, MACH - 313 BRG	1.000 EA
HA4051A00	PLASTIC CAP FOR GREASE FITTING	1.000 EA
HW4500A17	317400 ALEMITE GREASE RELIEF	1.000 EA
10XN5013K44	1/2-13 X 2.75 HEX HD GRADE 5	4.000 EA
HW1001A50	LOCKWASHER 1/2, ZINC PLT.,.879 OD, .509 I	4.000 EA
HW4600B42	V-RING SLINGER 2.375 X 3.070 X .28 VITON	1.000 EA
12FH1501A01	DRIP COVER, MACH	1.000 EA

Parts List (continued)		
Part Number	Description	Quantity
HW3201A13	.62-11 EYEBOLT W/2.00 SHANK	2.000 EA
HW1000A62	WASHER, 5/8" FLAT USS	2.000 EA
HW1001A63	WASHER, 5/8 SPLIT LK, ZN	2.000 EA
10CB3500SP	CONDUIT BOX LID, CAST	1.000 EA
10GS1000SP	GASKET, CONDUIT BOX LID	1.000 EA
51XW2520A12	.25-20 X .75, TAPTITE II, HEX WSHR SLTD	4.000 EA
HW1001A25	LOCKWASHER 1/4, ZINC PLT .493 OD, .255 I	4.000 EA
HW2501G32	KEY, 3/8 SQ X 3.750	1.000 EA
HW4500A03	GREASE FITTING, .125 NPT 1610(ALEMITE) 8	1.000 EA
HW4500A17	317400 ALEMITE GREASE RELIEF	1.000 EA
MJ1000A02	GREASE, MOBIL POLYREX EM - 124047	0.200 LB
HW4500A03	GREASE FITTING, .125 NPT 1610(ALEMITE) 8	1.000 EA
MG1000G27	MED CHARCOAL METALLIC GREY 400-0096	0.080 GA
85XU0407S04	4X1/4 U DRIVE PIN STAINLESS	2.000 EA
LB1182	WARNING LABEL FOR MOTORS WITH EYENUTS	1.000 EA
MN416A01	TAG-INSTAL-MAINT no wire (1200/bx) 3/19	1.000 EA
LB1119N	WARNING LABEL	1.000 EA
LC0181	CONNECTION LABEL	1.000 EA
NP1256L	ALUM UL CSA CC INDUSTRIAL MOTOR A60	1.000 EA
10PA1020	PACKAGING GROUP, BLANK PK1151	1.000 EA

AC Induction Motor Performance Data

Record # 29638 - Typical performance - not guaranteed values

Winding: 12WGY177-R002	Type: 1248M	Enclosure: OPEN
-------------------------------	--------------------	------------------------

Nameplate Data				460 V, 60 Hz: High Voltage Connection	
Rated Output (HP)	50			Full Load Torque	74.3 LB-FT
Volts	208-230/460			Start Configuration	direct on line
Full Load Amps	124-114/57			Breakdown Torque	269 LB-FT
R.P.M.	3540			Pull-up Torque	98.5 LB-FT
Hz	60	Phase	3	Locked-rotor Torque	117 LB-FT
NEMA Design Code	B	KVA Code	G	Starting Current	367 A
Service Factor (S.F.)	1.15			No-load Current	14.5 A
NEMA Nom. Eff.	92.4	Power Factor	89	Line-line Res. @ 25°C	0.117 Ω
Rating - Duty	40C AMB-CONT			Temp. Rise @ Rated Load	74°C
S.F. Amps				Temp. Rise @ S.F. Load	88°C
				Locked-rotor Power Factor	21
				Rotor inertia	3.76 LB-FT ²

Load Characteristics 460 V, 60 Hz, 50 HP

% of Rated Load	25	50	75	100	125	150	S.F.
Power Factor	67	83	88	90	90	90	90
Efficiency	86.4	91.4	92.7	92.4	91.8	90.6	92
Speed	3585	3572	3557	3541	3523	3500	3530
Line amperes	20.2	30.9	43.2	56.6	71	89.1	65.2

Performance Graph at 460V, 60Hz, 50.0HP Typical performance - Not guaranteed values

ABB Motors and Mechanical Inc.

WINDING # 12WGY177

Typical performance - not guaranteed values.

50 HP 3 PH 60 HZ 3540 RPM 460 V 1248M

TORQUES(LB-FT): PO=269 PU=98.5 LR=117 LRA=367

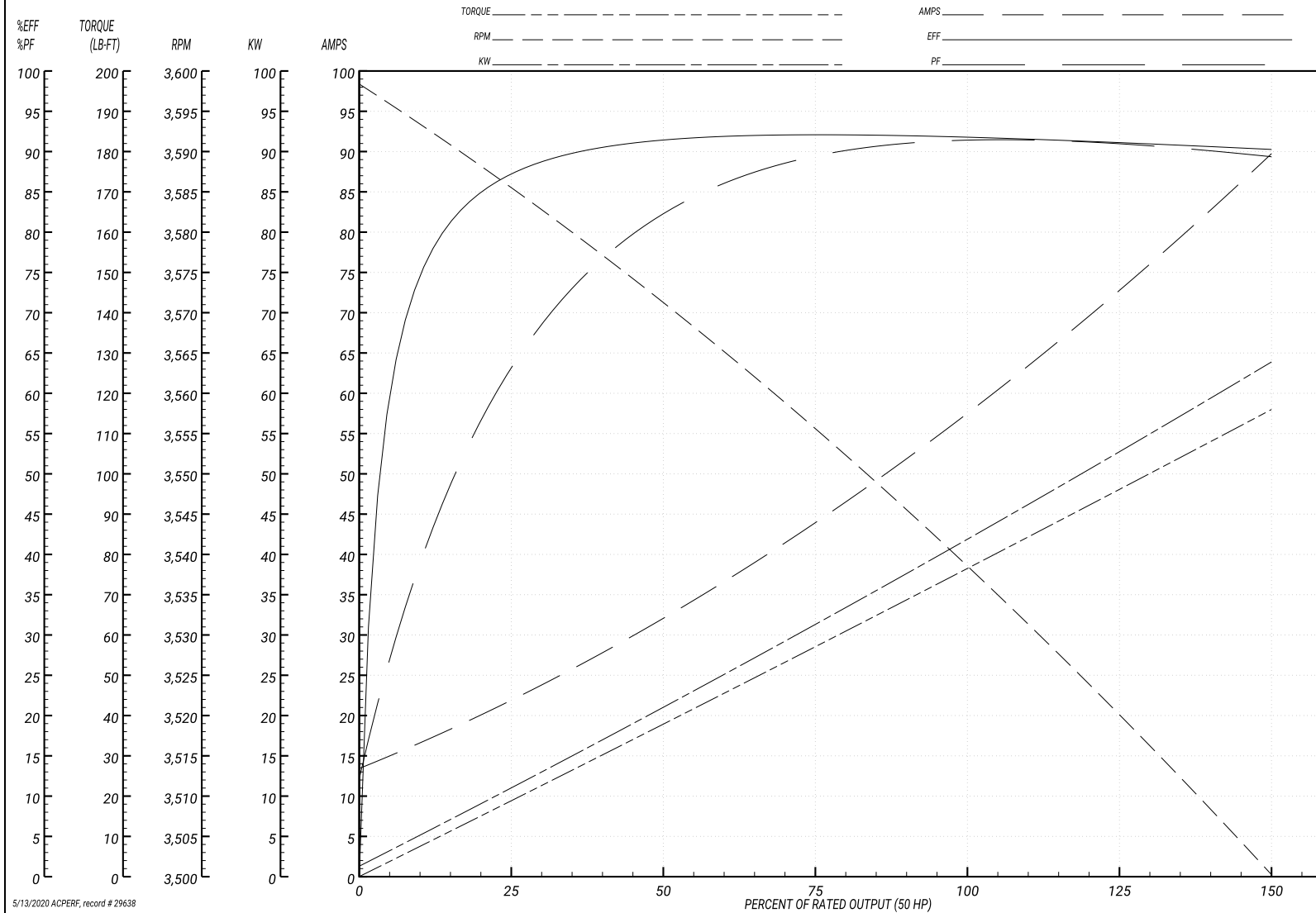

5/13/2020 ACPERF, record # 29638

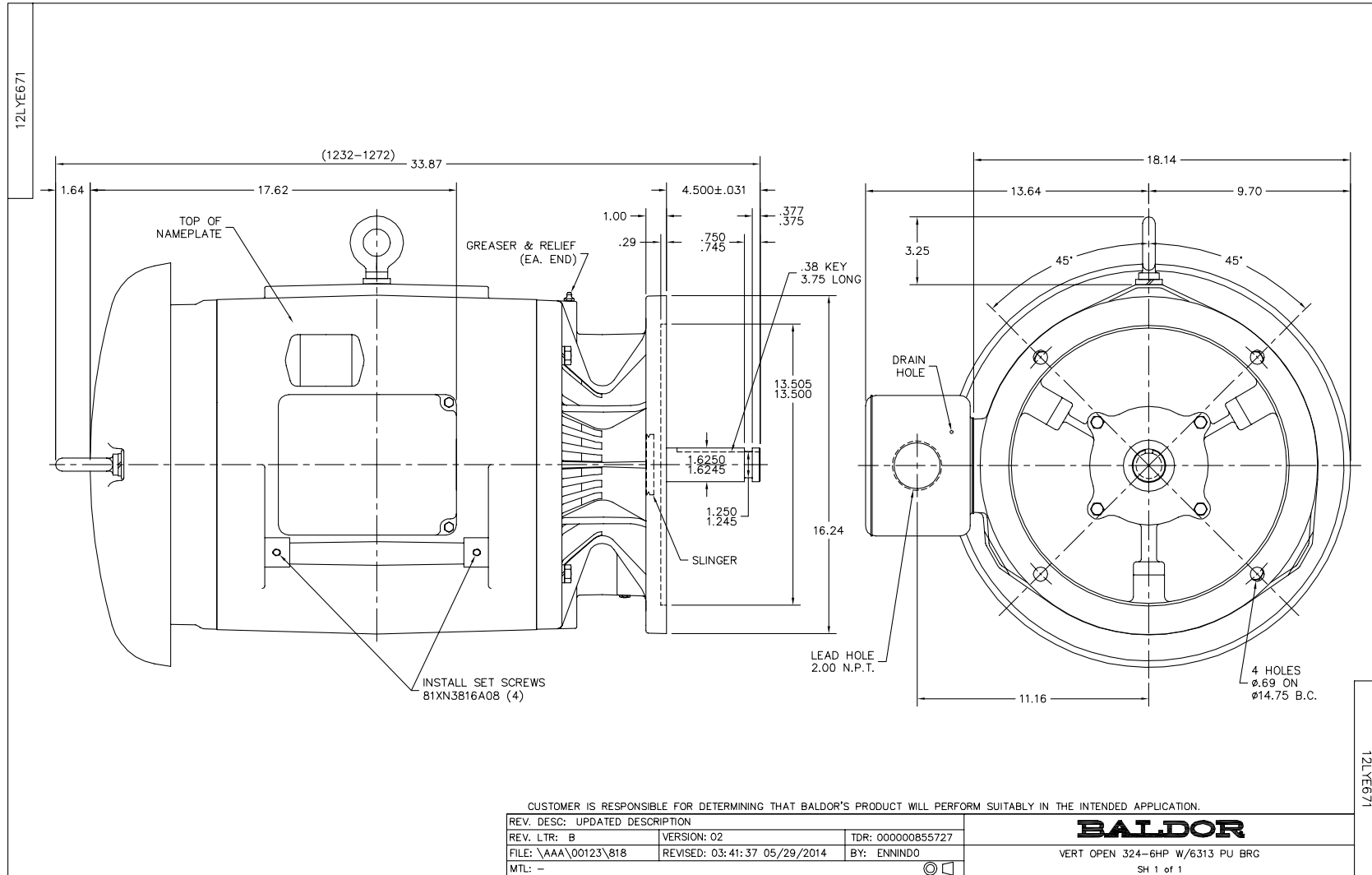

CD0180



LOW VOLTAGE
(2D)



HIGH VOLTAGE
(1D)



NOTES:

1. INTERCHANGE ANY TWO LINE LEADS TO REVERSE ROTATION.
2. OPTIONAL THERMOSTATS ARE PROVIDED WHEN SPECIFIED.
3. ACTUAL NUMBER OF INTERNAL PARALLEL CIRCUITS MAY BE A MULTIPLE OF THOSE SHOWN ABOVE.
4. LEAD COLORS ARE OPTIONAL. LEADS MUST ALWAYS BE NUMBERED AS SHOWN.

CD0180

REV. DESC: ADD CLASS CONN00000007		
REV. LTR: D	VERSION: 01	TDR: 000001099922
FILE: \AAA\00005\148	REVISED: 10:25:29 02/19/2019	BY: ENBRIRO
MTL: -	© □	

BALDOR - RELIANCE®

3PH, DV, 9 LEADS, DELTA CONNECTION

SH 1 of 1